

ICC-ES Evaluation Report

ESR-4504

Reissued December 2023

Subject to renewal December 2025

ICC-ES Evaluation Reports are not to be construed as representing aesthetics or any other attributes not specifically addressed, nor are they to be construed as an endorsement of the subject of the report or a recommendation for its use. There is no warranty by ICC Evaluation Service, LLC, express or implied, as to any finding or other matter in this report, or as to any product covered by the report.

Copyright © 2023 ICC Evaluation Service, LLC. All rights reserved.

<p>DIVISION: 06 00 00 — WOOD, PLASTICS AND COMPOSITES</p> <p>Section: 06 05 23 — Wood, Plastic, and Composite Fastenings</p>	<p>REPORT HOLDER: LEVI'S BUILDING COMPONENTS</p>	<p>EVALUATION SUBJECT: FRAMEGRIP WOOD SCREWS</p>	
--	---	---	---

1.0 EVALUATION SCOPE

Compliance with the following codes:

- 2012, 2009 and 2006 [International Building Code® \(IBC\)](#)
- 2012, 2009 and 2006 [International Residential Code® \(IRC\)](#)

Property evaluated:

Structural

2.0 USES

The FrameGrip wood screws are used for wood-to-wood connections that are designed in accordance with the IBC and IRC.

3.0 DESCRIPTION

3.1 General:

The FrameGrip wood screws are partially-threaded, self-drilling dowel-type screws designed to be installed in wood without drilling a lead hole. The screws have rolled threads and flat washer-like heads. The screws must be installed using a drill in the rotary mode only.

The FrameGrip screws have a hex washer head or a wafer head with a Torx drive recess and have a U thread design above the primary threads. The dimensions of the screws are shown in [Tables 1, 2](#) and [3](#), and images of the screws are shown in [Figures 1, 2](#) and [3](#).

3.2 Materials:

3.2.1 FrameGrip Wood Screws: The screws are manufactured from C10B21 steel with supplementary heat treatment. The FrameGrip hex washer head screws have a Cr3 acidic zinc plating and an E-coating in black. The FrameGrip wafer head screws (TORX 30⁵/₁₆ and TORX 40³/₈) screws have a Cr3 acidic zinc coating and Nano Gold + Wax coating, which is available in multiple colors including blue, white, silver, and bronze.

3.2.2 Wood Members: Three species of wood side and main members are addressed in this report: Douglas Fir-Larch (DFL), Southern Pine (SP) and Spruce-Pine-Fir (SPF). Wood side and main members must have a moisture content of less than 19 percent both at time of screw installation, and in service. Douglas Fir-Larch (DFL) wood members must have an assigned specific gravity of 0.50. Southern Pine (SP) wood members must have an assigned specific gravity of 0.55 and Spruce-Pine Fir (SPF) wood members must have an assigned specific gravity of 0.42 or greater.

The thickness of the wood main member, t_m , must be equal to or greater than the screw length, less the thickness of the side member. For wood-to-wood connections, the actual thickness of the wood side member, t_s , must be 1½ inches (38.1 mm), as specified in [Table 4](#). The wood side member thickness is an actual value and is not a minimum or maximum value.

4.0 DESIGN AND INSTALLATION

4.1 Design:

Reference lateral and withdrawal design values in the report are for allowable stress design, and must be multiplied by all applicable adjustment factors, as applicable to wood screws, in accordance with the NDS to determine adjusted design values. When designing a connection, the structural members must be checked for load-carrying capacity in accordance with Section 10.1.2 of the NDS, and local stresses within multiple-fastener connections must be checked against Appendix E of the NDS to ensure the capacity of the connection and fastener group. Connections containing multiple screws must also be designed in accordance with Sections 10.2.2 and 11.6 of the NDS. Where the screws are subjected to combined lateral and withdrawal loads, connections shall be designed in accordance with Section 11.4.1 of the NDS. Structural members forming the connection must be designed in accordance with the code.

Reference lateral (Z) design values for Levi's Building Components wood screws for single shear wood-to-wood connections loaded parallel to grain are shown in [Table 4](#), reference withdrawal (W) design values are shown in [Table 5](#), and reference head pull-through values are shown in [Table 7](#).

The allowable lateral load for a single-screw connection must be the lesser of: (a) the reference lateral design values given in [Table 4](#), adjusted by all applicable adjustment factors, and (b) the allowable screw shear strength given in [Table 1](#), [2](#), or [3](#), as applicable. The allowable load for a single-screw connection in which the screw is subject to tension must be the least of: (a) the reference withdrawal design load value given in [Table 5](#), adjusted by all applicable adjustment factors; (b) the reference head pull-through design value given in [Table 7](#), adjusted by all applicable factors; and (c) the allowable screw tension strength given in [Table 1](#), [2](#), or [3](#), as applicable.

4.2 Installation:

FrameGrip hex washer head wood screws must be installed with a 5/16-inch (7.94 mm) hex head driver and a low-speed drill. Installation may be performed without predrilling wood members. FrameGrip wafer head wood screws must be installed with a star driver. Edge distances, end distances and spacing of the screws must be sufficient to prevent splitting of the wood, or as required by [Table 6](#) of this report, whichever is more restrictive. The bottom of the screw heads must be installed flush to the surface of the member being connected. The screws must not be overdriven.

5.0 CONDITIONS OF USE

The FrameGrip wood screws described in this report comply with, or are suitable alternatives to what is specified in, those codes listed in Section 1.0 of this report, subject to the following conditions:

- 5.1 The screws must be installed in accordance with the report holder's published installation instructions and this report. In the case of a conflict between this report and the report holder's instructions, this report governs.
- 5.2 Calculations and details demonstrating compliance with this report must be submitted to the code official. The calculations and details must be prepared by a registered design professional where required by the statutes of the jurisdiction in which the project is to be constructed.
- 5.3 Use of the screws in contact with preservative-treated or fire-retardant-treated wood is outside the scope of this report.

6.0 EVIDENCE SUBMITTED

Data in accordance with the [ICC-ES Acceptance Criteria for Alternate Dowel-type Threaded Fasteners \(AC233\)](#), dated June 2014.

7.0 IDENTIFICATION

- 7.1 The packaging for the FrameGrip wood screws is labeled with the designation FrameGrip, the drive type and size, an image of the screw showing the head style, the report holder (Levi's Building Components) name and address, the fastener size, and the ICC-ES evaluation report number (ESR-4504). Each screw head is marked with the letters "LBC".

7.2 The report holder’s contact information is the following:

LEVI’S BUILDING COMPONENTS
400 BURKHOLDER DRIVE
EPHRATA, PENNSYLVANIA 17522
(877) 897-7020
www.levisbuildingcomponents.com

TABLE 1—FRAMEGRIP HEX WASHER HEAD WOOD SCREW SPECIFICATIONS

DESIGNATION	OVERALL LENGTH ¹ , L (inches)	THREAD LENGTH ² , T (inches)	UNTHREADED SHANK DIAMETER (inch)	MINOR THREAD (ROOT) DIAMETER D _r (inch)	OUTSIDE THREAD DIAMETER (inch)	BENDING YIELD ³ F _{yb} (psi)	ALLOWABLE STEEL STRENGTH	
							TENSION (lbf)	SHEAR (lbf)
1/4 X 2 1/4	2 1/4	1 1/4	0.196	0.174	0.265	115,500	1,460	1,010
1/4 X 4	4	2 1/2						
1/4 X 6	6							
1/4 X 8	8							
1/4 X 10	10							
1/4 X 12	12							
1/4 X 14	14							
1/4 X 16	16							

For SI: 1 inch = 25.4 mm, 1 psi = 6.89 kPa, 1 lbf = 4.45 N.

¹Overall length is measured from the underside of head to bottom of tip.

²Length of thread includes tip.

³Bending yield strengths determined in accordance with ASTM F1575 using the minor thread (root) diameter, D_r.

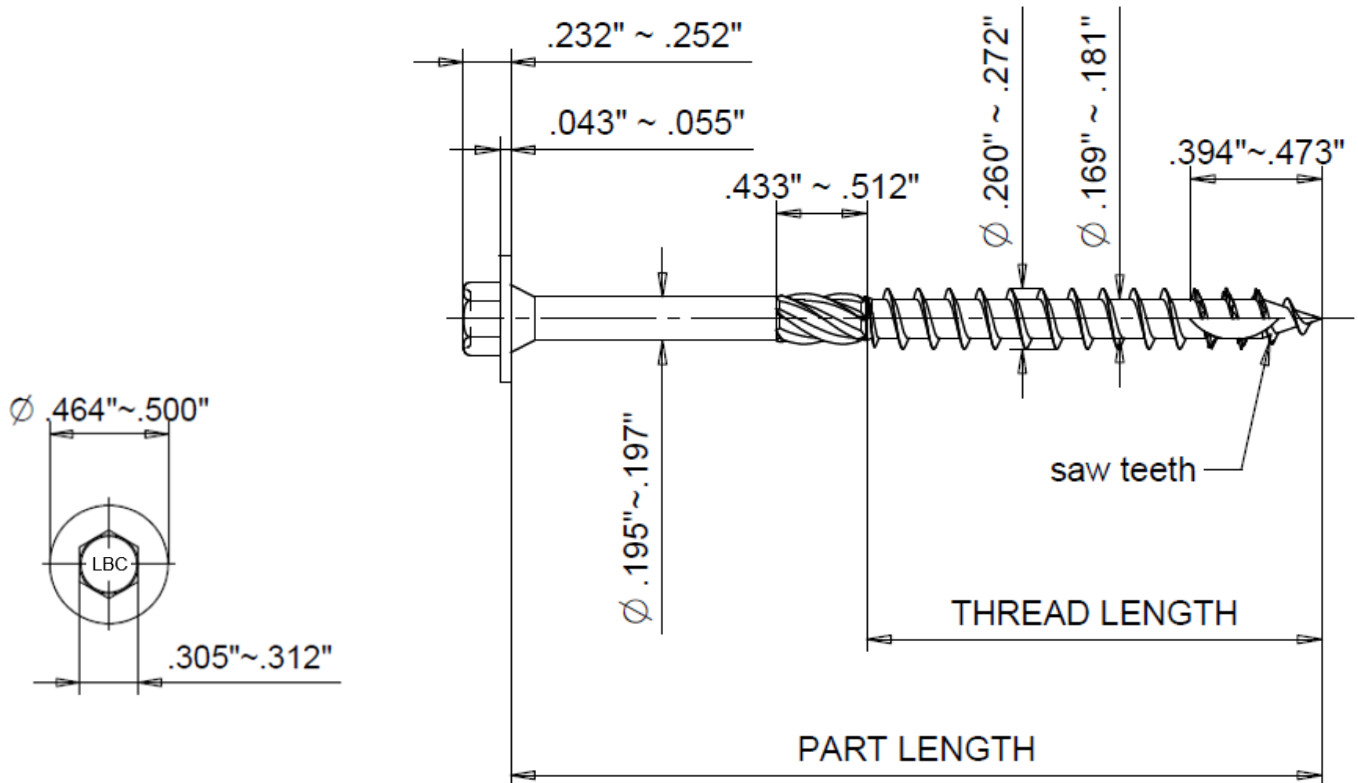

FIGURE 1—FRAMEGRIP HEX WASHER HEAD WOOD SCREWS

TABLE 2—FRAMEGRIP WAFER HEAD TORX 30 WOOD SCREW SPECIFICATIONS

DESIGNATION	OVERALL LENGTH ¹ , L (inches)	THREAD LENGTH ² , T (inches)	UNTHREADED SHANK DIAMETER (inch)	MINOR THREAD (ROOT) DIAMETER D _r (inch)	OUTSIDE THREAD DIAMETER (inch)	BENDING YIELD ³ F _{yb} (psi)	ALLOWABLE STEEL STRENGTH	
							TENSION (lbf)	SHEAR (lbf)
30 ⁵ / ₁₆ X 2	2	1½	0.201	0.175	0.275	110,700	1,315	920
30 ⁵ / ₁₆ X 2½	2½							
30 ⁵ / ₁₆ X 3	3	2						
30 ⁵ / ₁₆ X 3½	3½							
30 ⁵ / ₁₆ X 4	4	3						
30 ⁵ / ₁₆ X 5	5							
30 ⁵ / ₁₆ X 6	6	3½						
30 ⁵ / ₁₆ X 7	7							
30 ⁵ / ₁₆ X 8	8							

For SI: 1 inch = 25.4 mm, 1 psi = 6.89 kPa, 1 lbf = 4.45 N.

¹Overall length is measured from the underside of head to bottom of tip with a tolerance of ± 0.059 inches. See Figure 2.

²Length of thread includes tip with a tolerance of ± 0.039 inches. See Figure 2.

³Bending yield strengths determined in accordance with ASTM F1575 using the minor thread (root) diameter, D_r.

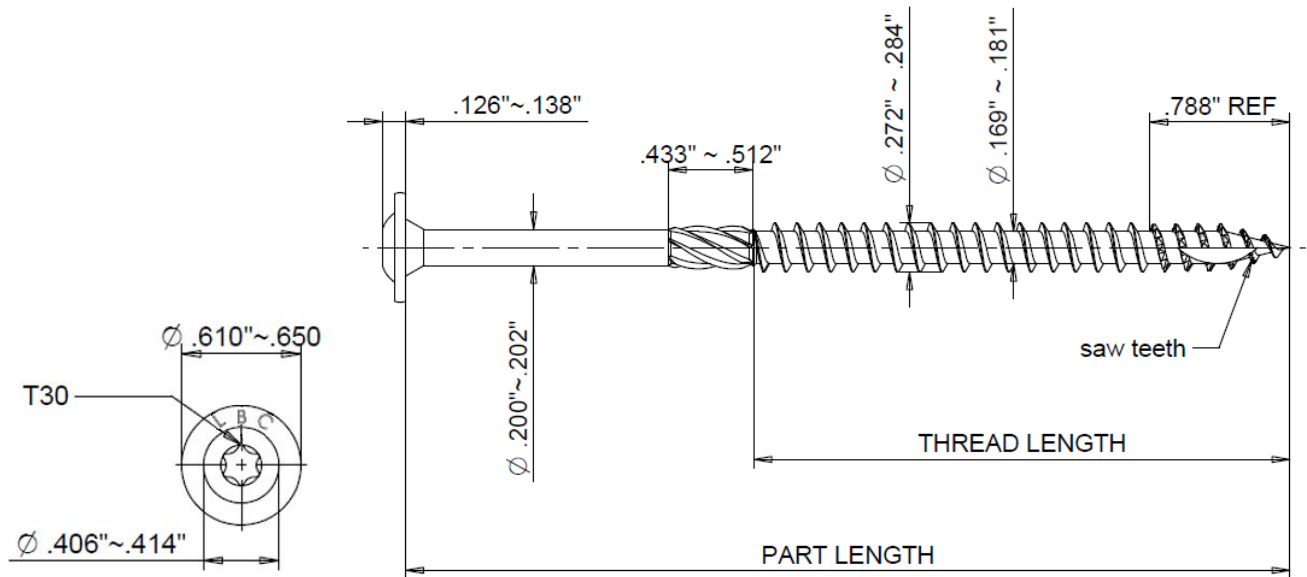

FIGURE 2—FRAMEGRIP WAFER HEAD TORX 30 WOOD SCREWS

TABLE 3—FRAMEGRIP WAFER HEAD TORX 40 WOOD SCREW SPECIFICATIONS

DESIGNATION	OVERALL LENGTH ¹ , L (inches)	THREAD LENGTH ² , T (inches)	UNTHREADED SHANK DIAMETER (inch)	MINOR THREAD (ROOT) DIAMETER D _r (inch)	OUTSIDE THREAD DIAMETER (inch)	BENDING YIELD ³ F _{yb} (psi)	ALLOWABLE STEEL STRENGTH	
							TENSION (lbf)	SHEAR (lbf)
40 ³ / ₈ X 7	7	3 ¹ / ₂	0.228	0.204	0.307	122,026	1,770	1,367
40 ³ / ₈ X 8	8	4						
40 ³ / ₈ X 10	10							
40 ³ / ₈ X 12	12							
40 ³ / ₈ X 14	14							
40 ³ / ₈ X 16	16							

For SI: 1 inch = 25.4 mm, 1 psi = 6.89 kPa, 1 lbf = 4.45 N.

¹Overall length is measured from the underside of head to bottom of tip with a tolerance of ± 0.059 inches. See Figure 3.

²Length of thread includes tip with a tolerance of ± 0.039 inches. See Figure 3.

³Bending yield strengths determined in accordance with ASTM F1575 using the minor thread (root) diameter, D_r.

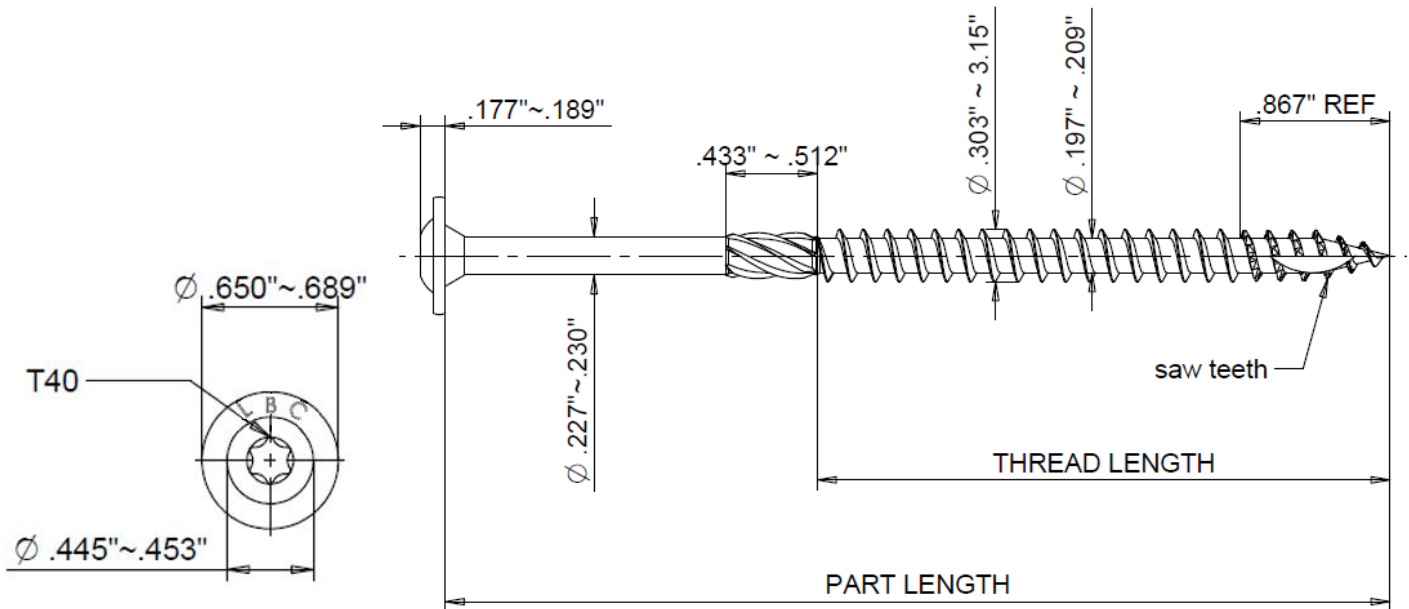

FIGURE 3—FRAMEGRIP WAFER HEAD TORX 40 WOOD SCREW

TABLE 4—REFERENCE LATERAL DESIGN VALUES (Z) FOR SINGLE SHEAR (TWO MEMBER) WOOD-TO-WOOD CONNECTIONS WITH LOADING PARALLEL TO GRAIN

FRAMEGRIP FASTENER DESIGNATION	OVERALL LENGTH ¹ , L (inches)	SIDE MEMBER THICKNESS <i>t_s</i> min. (inches)	Z ^{1,2,3,4} (lbf) FOR CONNECTIONS LOADED PARALLEL TO THE GRAIN FOR SPECIFIC GRAVITIES OF:		
			0.55 (Southern Pine)	0.50 (Douglas Fir-Larch)	0.42 (Spruce Pine Fir)
1/4 X 2 1/4	2 1/4	1 1/2	197	204	138
1/4 X 4	4		255	288	226
1/4 X 6	6		260	294	224
1/4 X 8	8				
1/4 X 10	10				
1/4 X 12	12				
1/4 X 14	14				
1/4 X 16	16				
30 ⁵ / ₁₆ X 2 1/2	2 1/2	1 1/2	345	314	293
30 ⁵ / ₁₆ X 3	3		372	351	343
30 ⁵ / ₁₆ X 3 1/2	3 1/2		372	351	343
30 ⁵ / ₁₆ X 4	4		386	364	352
30 ⁵ / ₁₆ X 5	5				
30 ⁵ / ₁₆ X 6	6				
30 ⁵ / ₁₆ X 7	7				
30 ⁵ / ₁₆ X 8	8				
40 ³ / ₈ X 7	7	448			
40 ³ / ₈ X 8	8				
40 ³ / ₈ X 10	10				
40 ³ / ₈ X 12	12				
40 ³ / ₈ X 14	14				
40 ³ / ₈ X 16	16				

For SI: 1 inch = 25.4 mm, 1 lbf = 4.45 N.

¹ Tabulated lateral design values (Z) must be multiplied by all applicable adjustment factors, including the load duration factor C_D, from the NDS as referenced in the IBC or IRC.

² The wood main member thickness must be equal to or greater than the screw length less the thickness of the wood side member.

³ Screws must be installed into the side grain of the wood members with the screw axis perpendicular to wood the fibers.

⁴ The tabulated lateral design values (Z) are based on wood members having the same or greater specific gravity as noted in [Table 4](#).

TABLE 5—REFERENCE WITHDRAWAL DESIGN VALUE (W) FOR SCREWS INSTALLED IN THE SIDE GRAIN OF A MAIN MEMBER HAVING A SPECIFIC GRAVITY PER THE TABLE OR GREATER

FRAMEGRIP FASTENER DESIGNATION	OVERALL LENGTH ¹ , L (inches)	THREAD LENGTH ¹ , T (inches)	REFERENCE WITHDRAWAL DESIGN VALUE ^{2, 3} , W					
			0.55 (Southern Pine)		0.50 (Douglas Fir-Larch)		0.42 (Spruce Pine Fir)	
			(lbf/in)	(lbf)	(lbf/in)	(lbf)	(lbf/in)	(lbf)
1/4 X 2 1/4	2 1/4	1 1/4	242	302	195	244	139	174
1/4 X 4	4	2 1/2		604		488		348
1/4 X 6	6	2 1/2						
1/4 X 8	8	2 1/2						
1/4 X 10	10	2 1/2						
1/4 X 12	12	2 1/2						
1/4 X 14	14	2 1/2						
1/4 X 16	16	2 1/2						
30 ⁵ / ₁₆ X 2 1/2	2 1/2	1 1/2	250	375	223	334	149	223
30 ⁵ / ₁₆ X 3	3	2		500		445		297
30 ⁵ / ₁₆ X 3 1/2	3 1/2	2						
30 ⁵ / ₁₆ X 4	4	2						
30 ⁵ / ₁₆ X 5	5	3						
30 ⁵ / ₁₆ X 6	6	3						
30 ⁵ / ₁₆ X 7	7	3 1/2						
30 ⁵ / ₁₆ X 8	8	3 1/2						
40 ³ / ₈ X 7	7	3 1/2	266	932	243	850	163	571
40 ³ / ₈ X 8	8	4		1065		971		652
40 ³ / ₈ X 10	10	4						
40 ³ / ₈ X 12	12	4						
40 ³ / ₈ X 14	14	4						
40 ³ / ₈ X 16	16	4						

For **SI**: 1 inch = 25.4 mm, 1 lbf/in = .175N/mm; 1 lbf = 4.45 N.

¹ Embedded thread length is that portion held in the main member including the screw tip.

² The tabulated reference withdrawal design value is in pounds with the specified thread length into the side grain of the main member.

³ The tabulated reference withdrawal design value must be multiplied by all applicable factors from the NDS as referenced in the IBC or IRC.

TABLE 6—CONNECTION GEOMETRY

CONDITION ¹		MINIMUM DISTANCE OR SPACING			
		DIAMETERS	Hex Washer Head (inches)	Wafer Head (Torx 30) (inches)	Wafer Head (Torx 40) (inches)
Edge Distance	Loading Parallel to grain	8	1½	1 ⁵ / ₈	1 ⁷ / ₈
End distance	Parallel to grain	18	3½	3 ⁵ / ₈	4 ¹ / ₈
Spacing	Between fasteners in a row	15	3	3	3 ¹ / ₈
	Between rows	5	1	1	1 ¹ / ₈
	Between staggered rows	2.5	½	½	⁵ / ₈

For **SI**: 1 inch = 25.4 mm

¹ Edge distances, end distances and spacing of screws must be sufficient to prevent splitting of the wood or as required by this table, whichever is the more restrictive.

TABLE 7—PULL THROUGH DESIGN VALUES (P)

FASTENER DESCRIPTION	P (lbf) HEAD PULL THROUGH		
	0.55 (Southern Pine)	0.50 (Douglas Fir-Larch)	0.42 (Spruce Pine Fir)
Hex Washer Head	312	324	226
Wafer Head (Torx 30)	488	520	360
Wafer Head (Torx 40)	566	572	400

For **SI**: 1 inch = 25.4 mm, 1 lbf = 4.45 N.